

PANTA REI

TELESCOPICO TELE T / TELESCOPIC TELE-T

(PRTT2-80 PRTT2-100)

ISTRUZIONI DI MONTAGGIO / ASSEMBLY INSTRUCTIONS

SENZA VETRO FISSO / WITHOUT FIXED GLASS

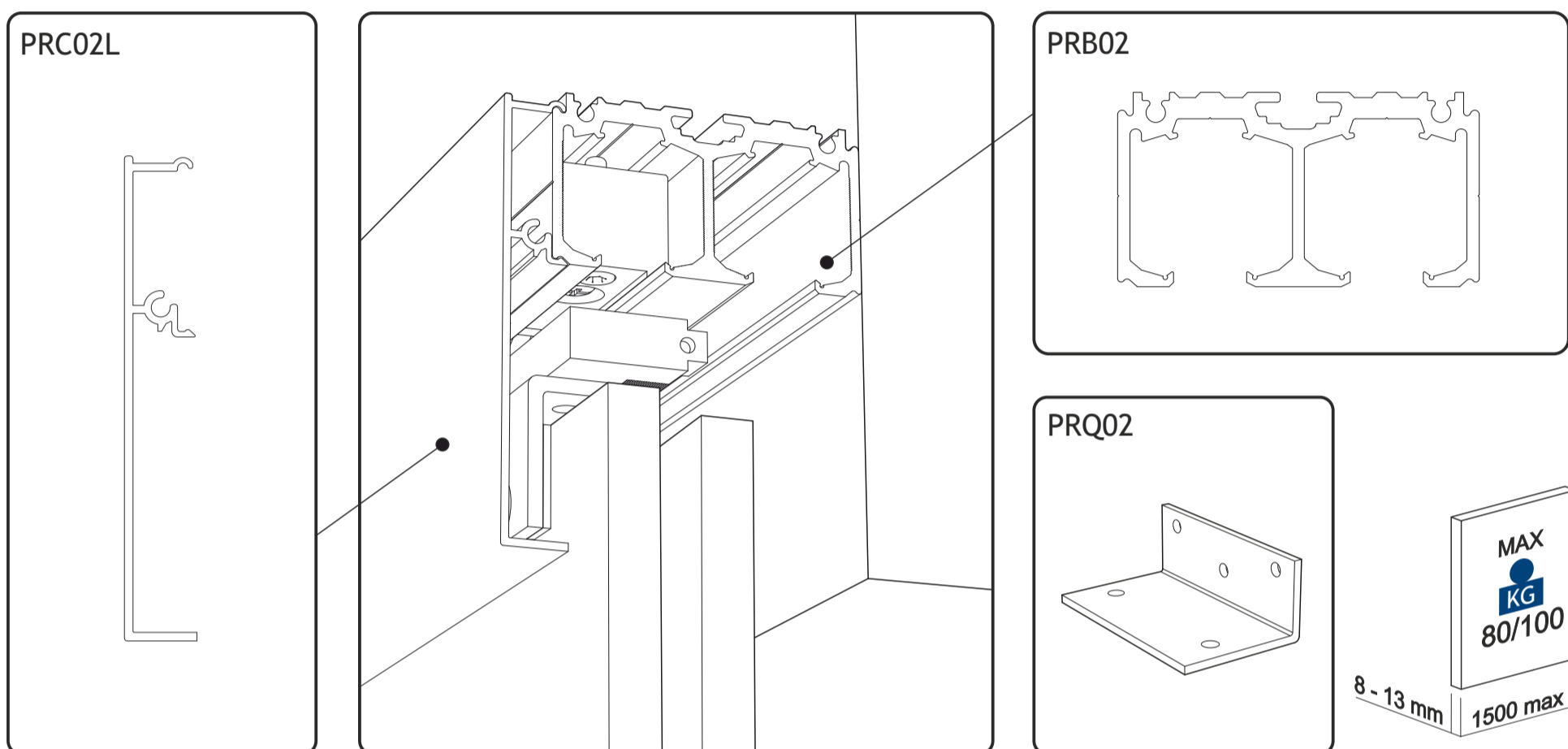

CON VETRO FISSO / WITH FIXED GLASS

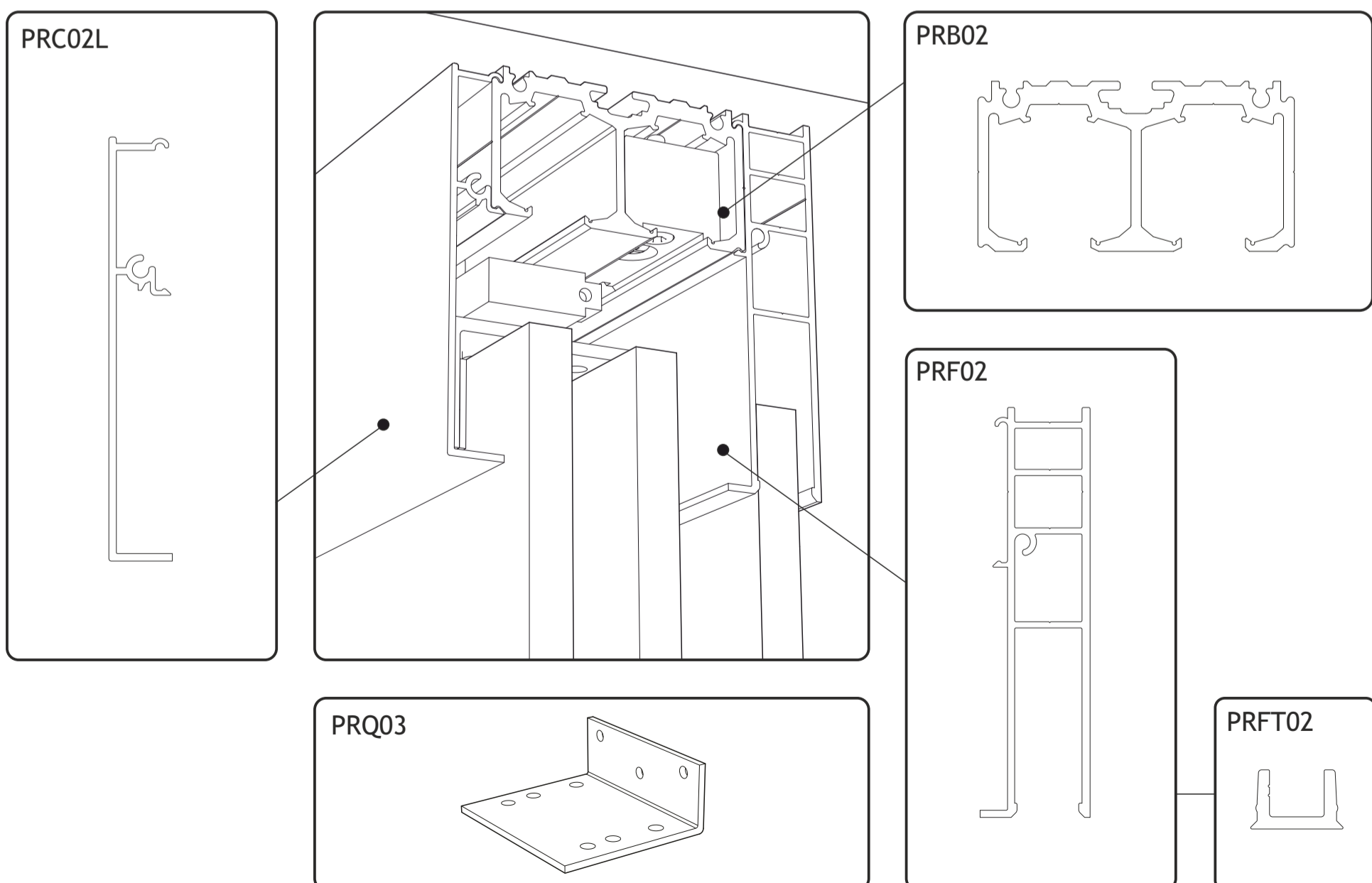

PRTT2-80 PANTA REI TELE-T KIT A 2 ANTE TELESCOPICHE / 2 TELESCOPIC LEAFS

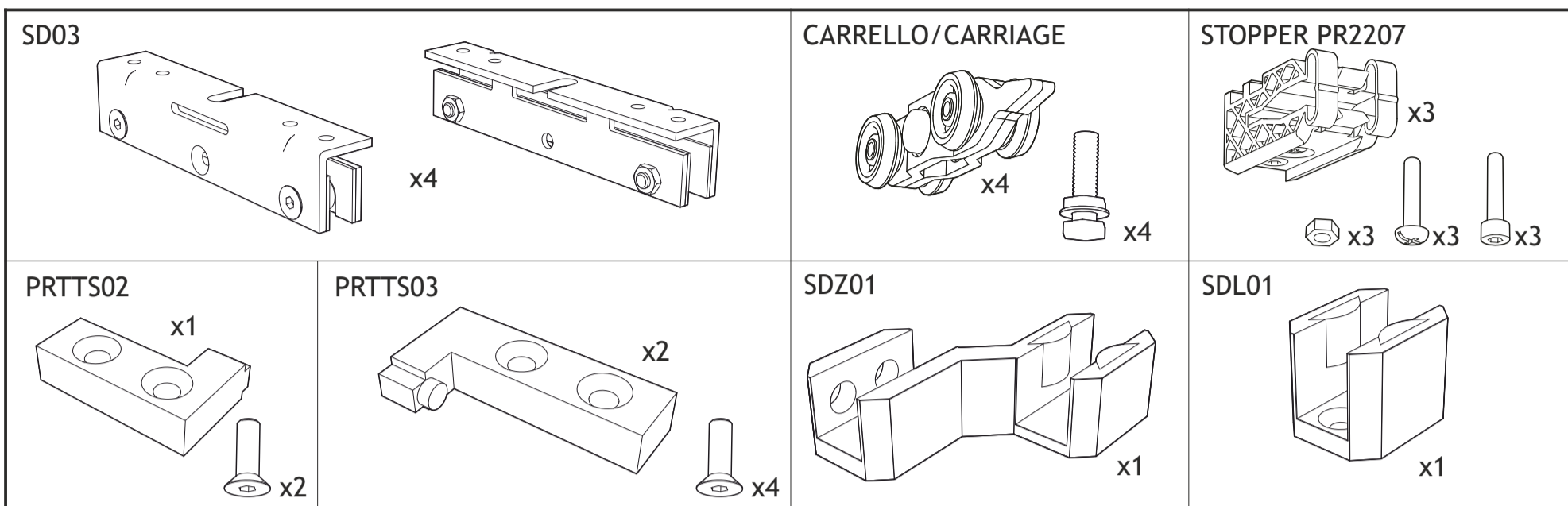

PRTT2-100 PANTA REI TELE-T KIT 2 ANTE TELESCOPICHE / 2 TELESCOPIC LEAFS

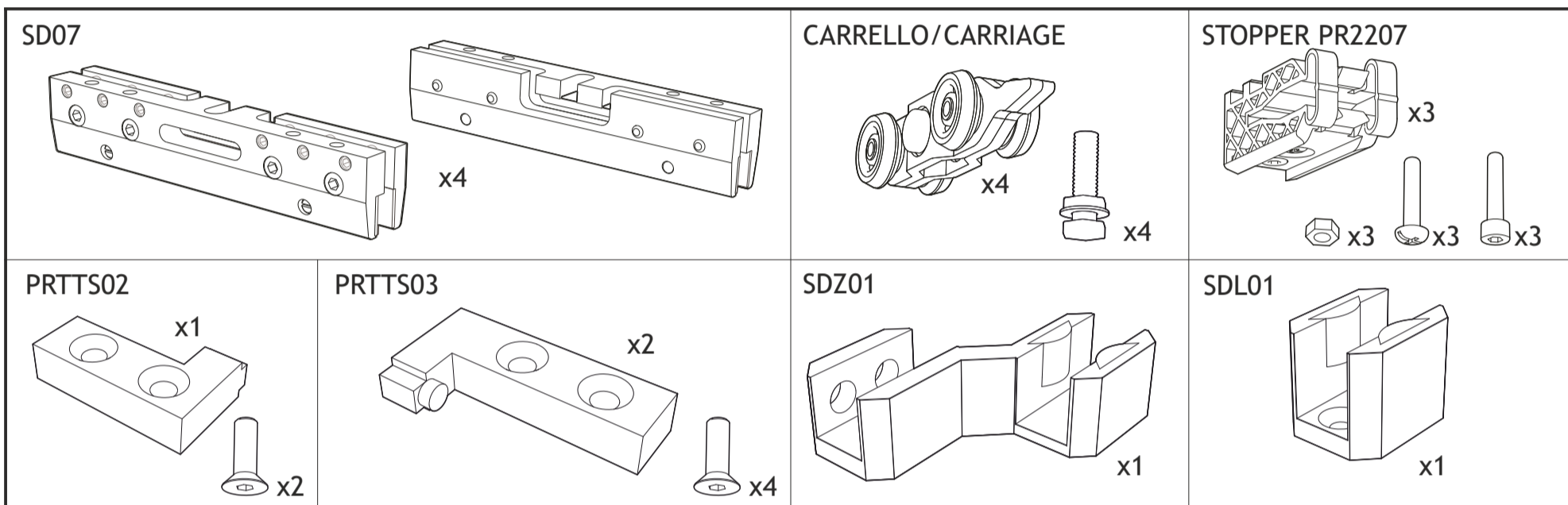

A PARETE / TO WALL

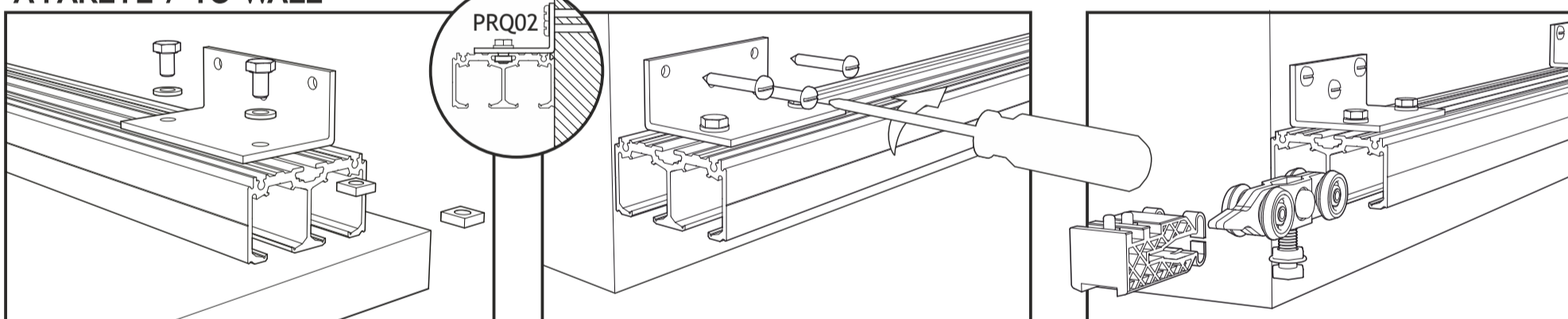

A PARETE CON FISSO / TO WALL WITH FIXED GLASS

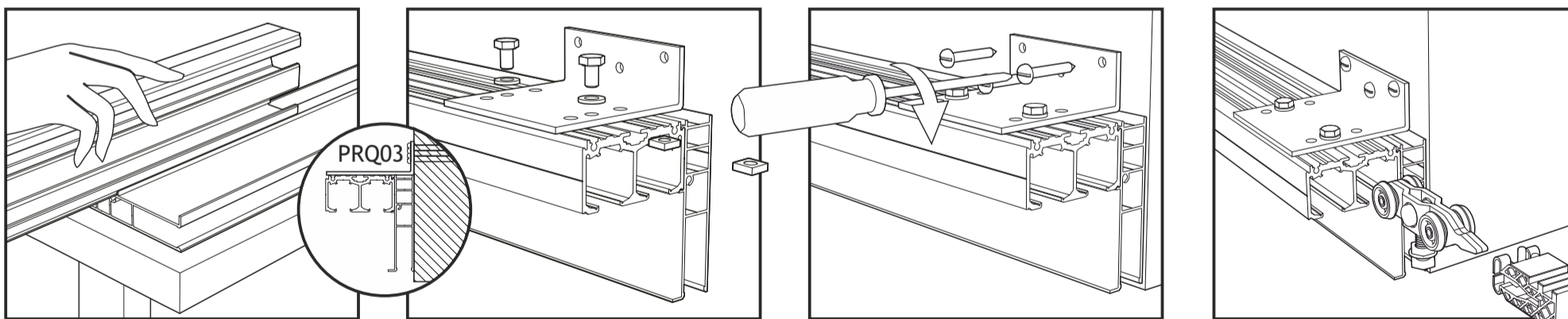

A SOFFITTO / TO CEILING

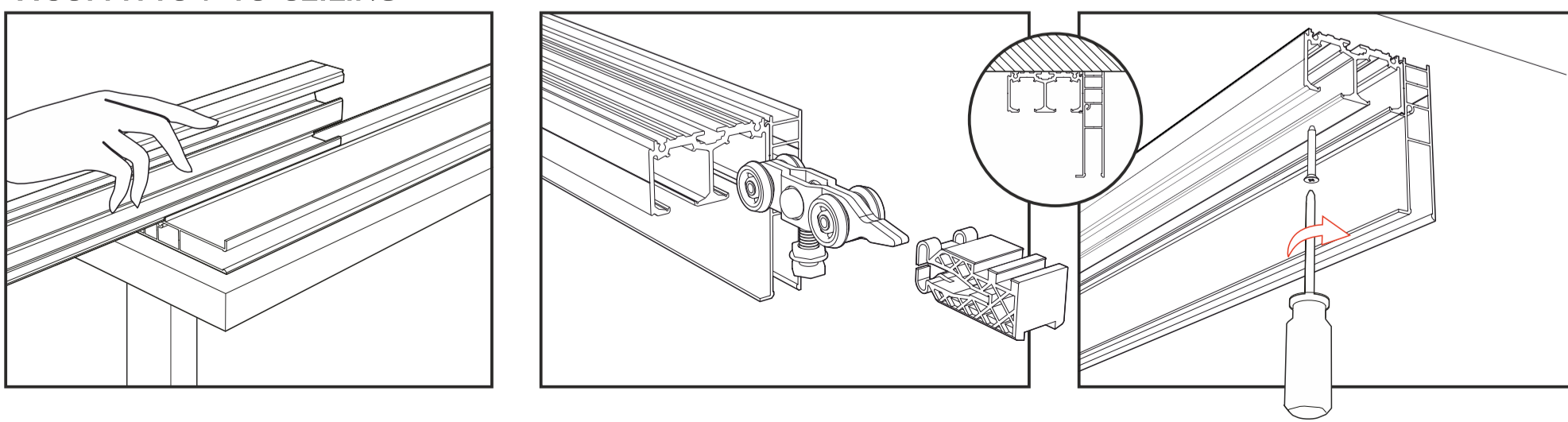

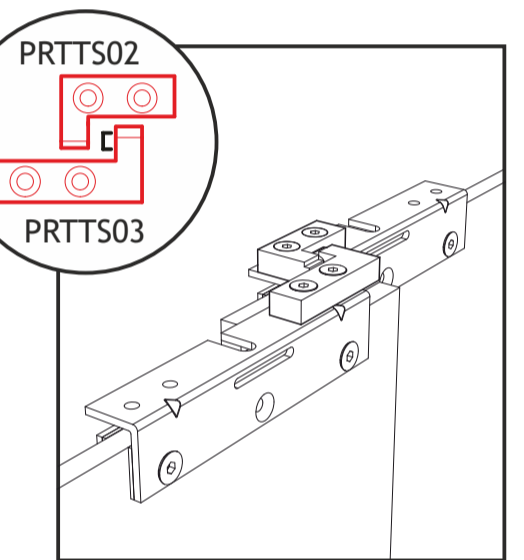
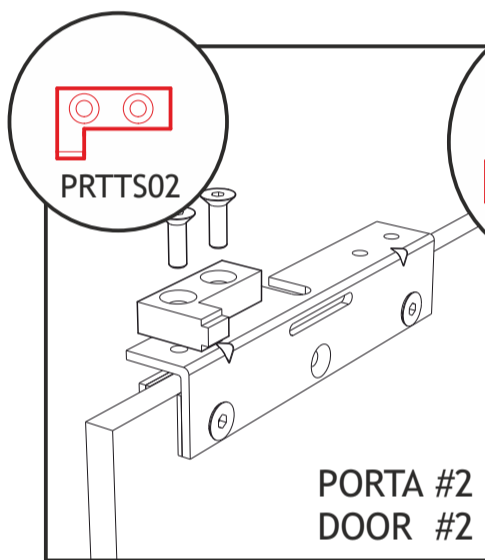
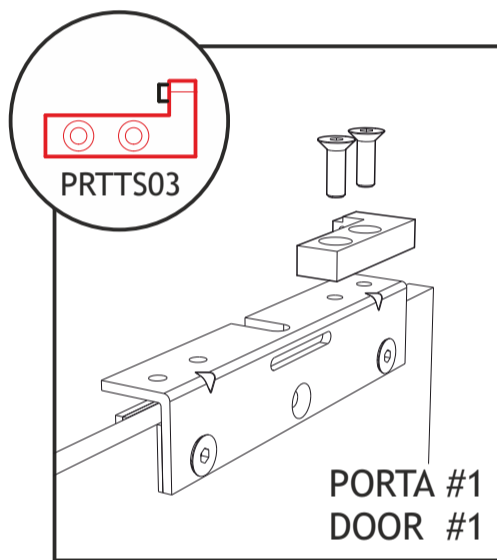
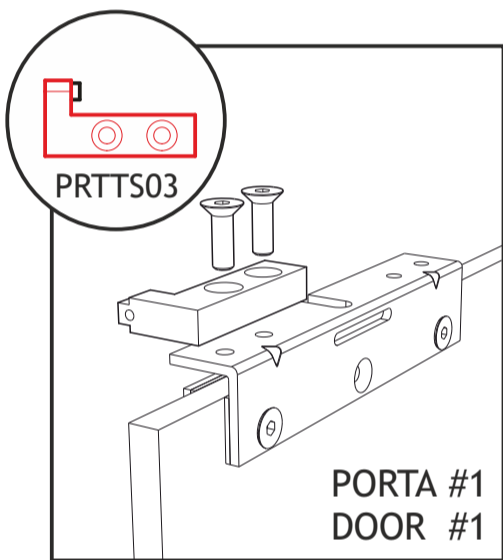
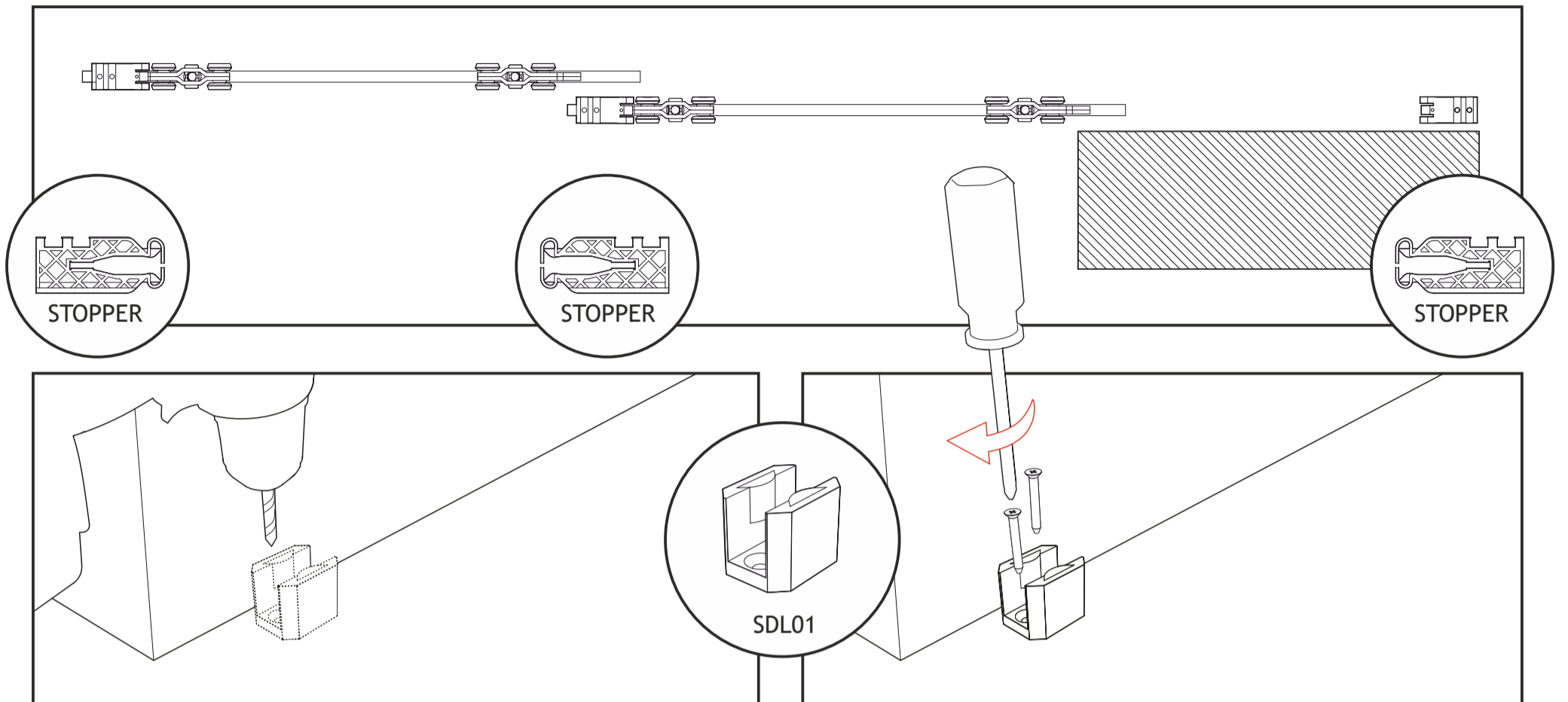

PER SD07 FOR SD07

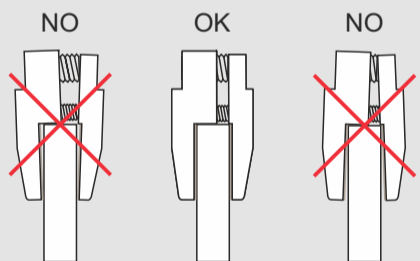

IMPORTANTE: durante l'installazione delle pinze verificare che le ganasce siano sempre complanari alla superficie del vetro come rappresentato nella figura centrale.

IMPORTANT: during the installation of the clamps, the jaws must be always coplanar to the glass surface as shown in the central figure.

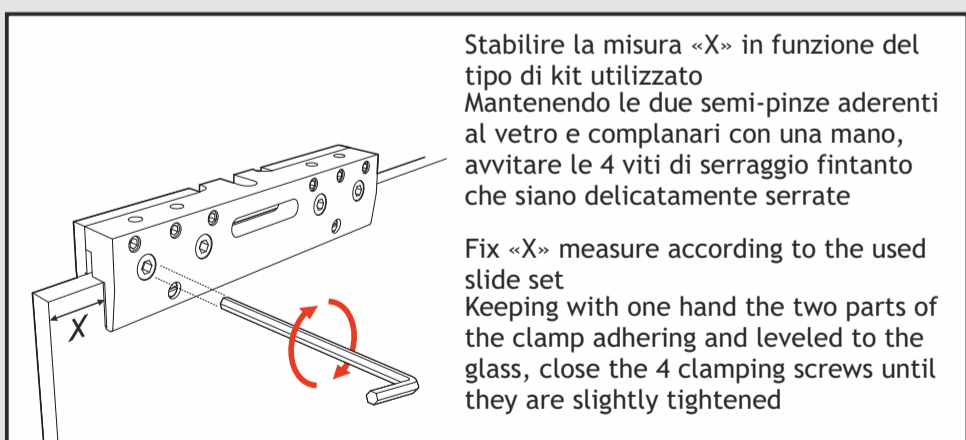

Stabilire la misura «X» in funzione del tipo di kit utilizzato
Mantenendo le due semi-pinze aderenti al vetro e complanari con una mano, avvitare le 4 viti di serraggio fintanto che siano delicatamente serrate

Fix «X» measure according to the used slide set
Keeping with one hand the two parts of the clamp adhering and leveled to the glass, close the 4 clamping screws until they are slightly tightened

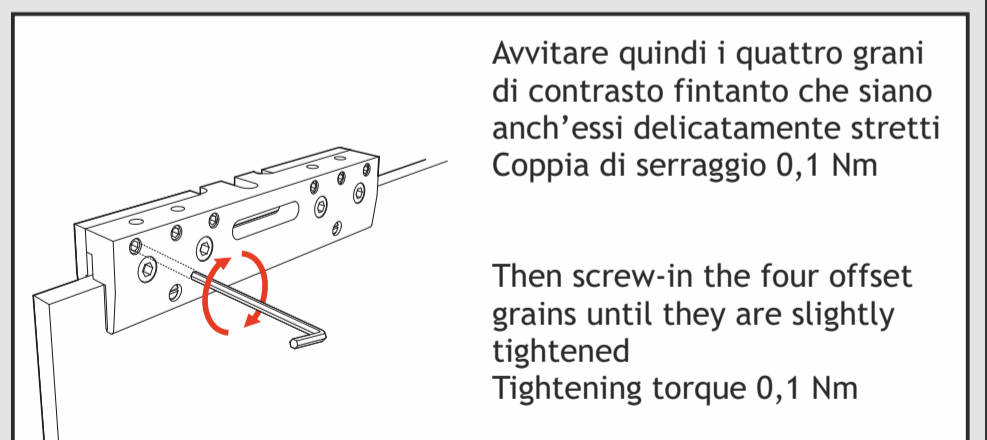

Avvitare quindi i quattro grani di contrasto fintanto che siano anch'essi delicatamente stretti
Coppia di serraggio 0,1 Nm

Then screw-in the four offset grains until they are slightly tightened
Tightening torque 0,1 Nm

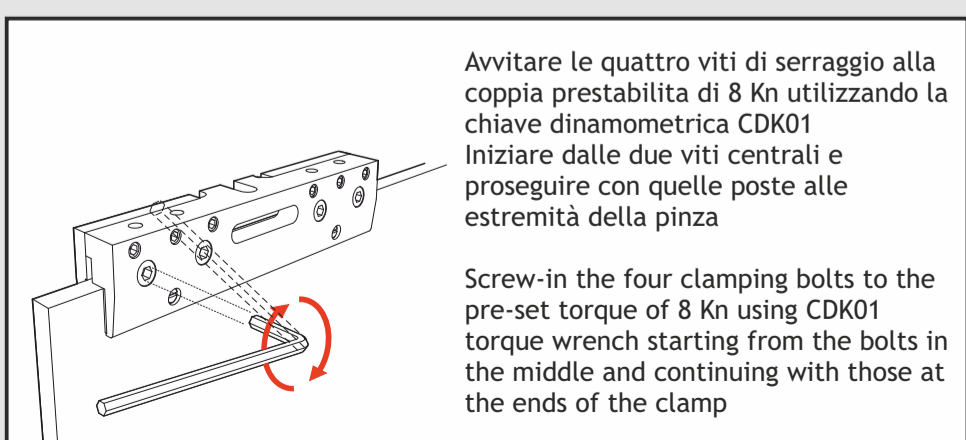

Avvitare le quattro viti di serraggio alla coppia prestabilita di 8 Kn utilizzando la chiave dinamometrica CDK01
Iniziare dalle due viti centrali e proseguire con quelle poste alle estremità della pinza

Screw-in the four clamping bolts to the pre-set torque of 8 Kn using CDK01 torque wrench starting from the bolts in the middle and continuing with those at the ends of the clamp

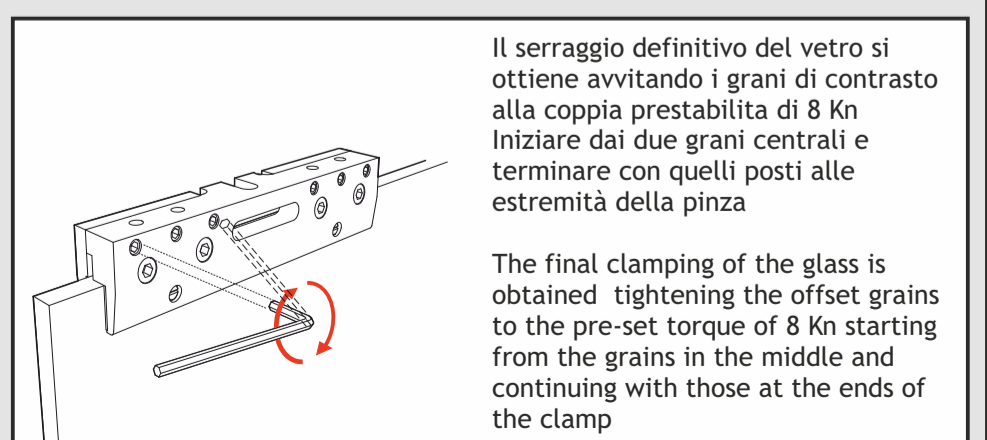

Il serraggio definitivo del vetro si ottiene avvitando i grani di contrasto alla coppia prestabilita di 8 Kn
Iniziare dai due grani centrali e terminare con quelli posti alle estremità della pinza

The final clamping of the glass is obtained tightening the offset grains to the pre-set torque of 8 Kn starting from the grains in the middle and continuing with those at the ends of the clamp

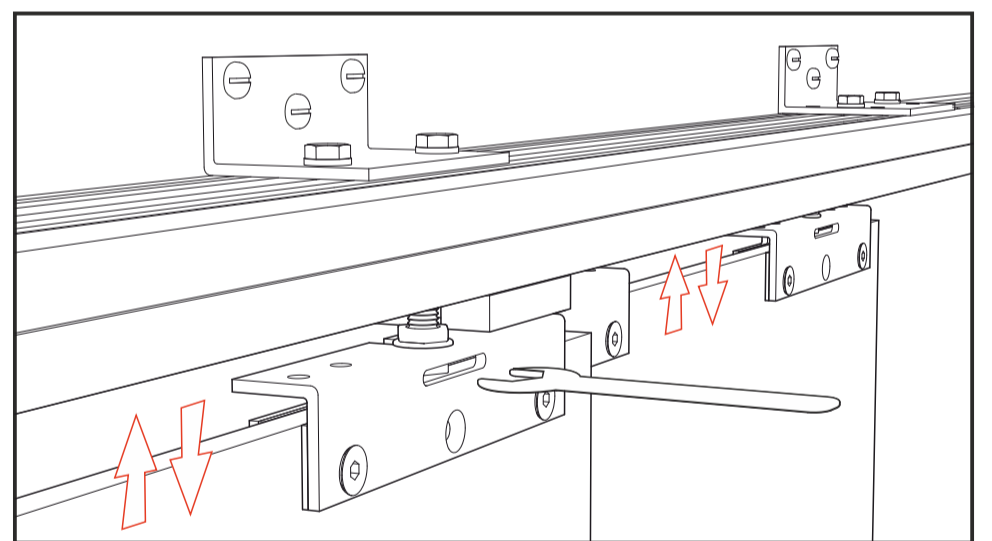
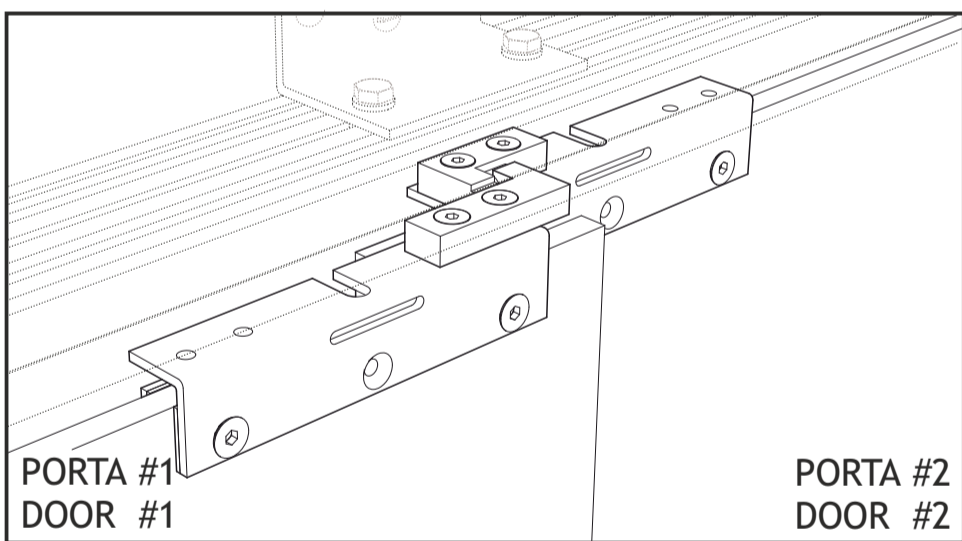
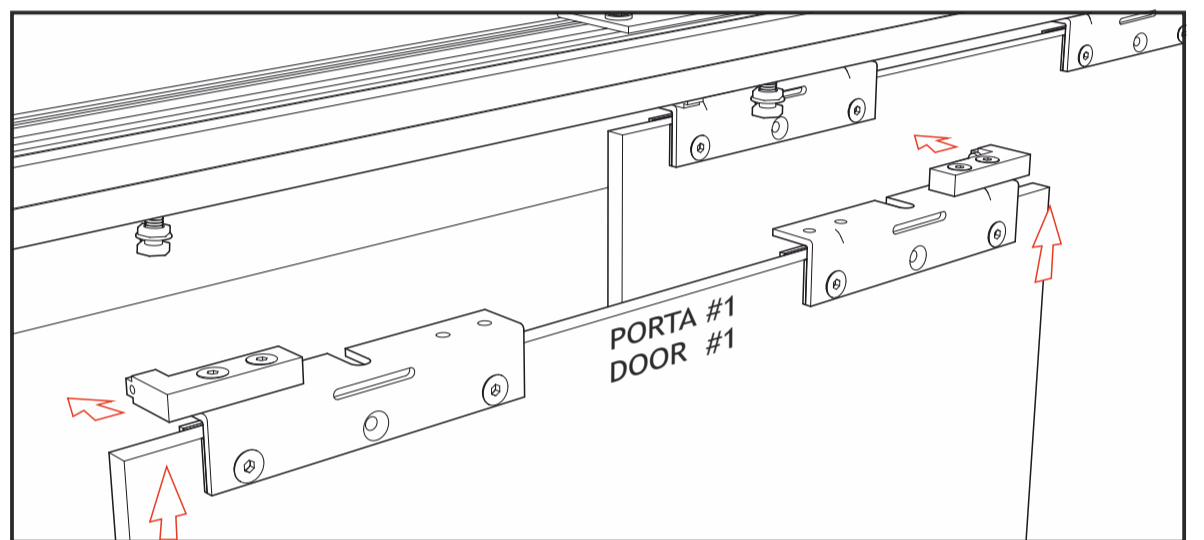
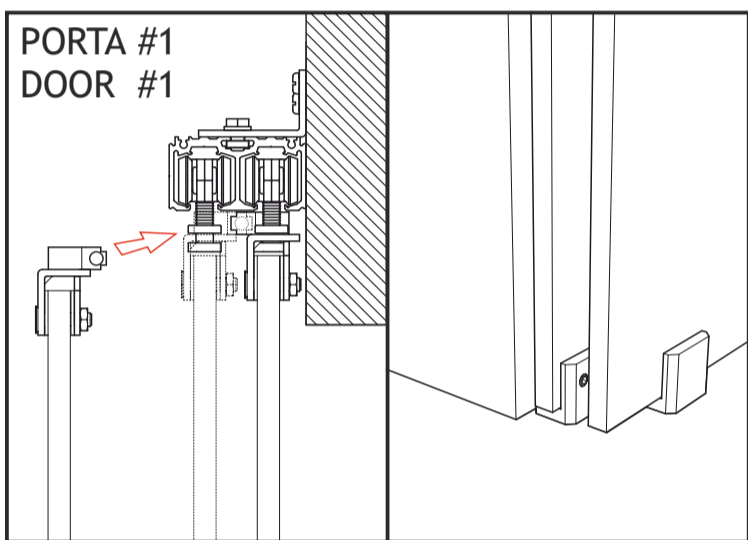
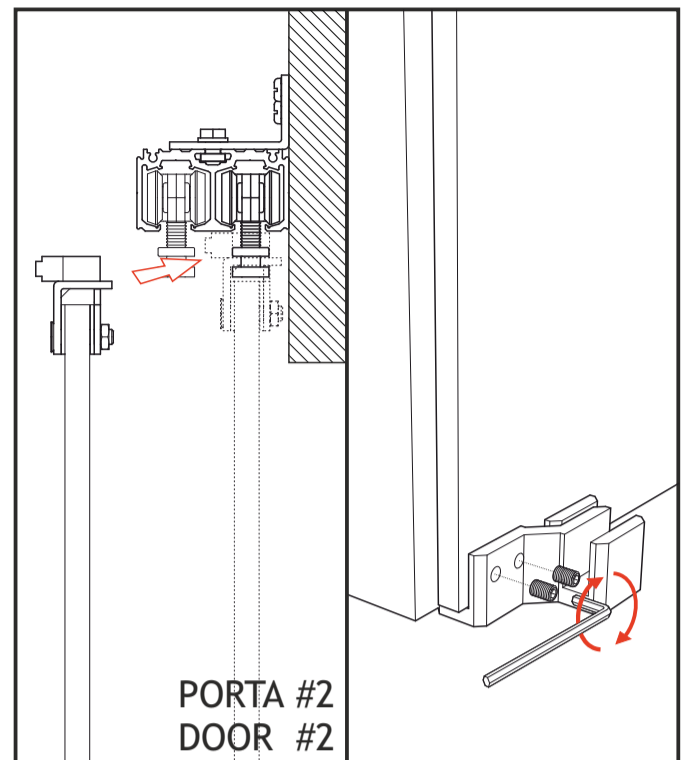
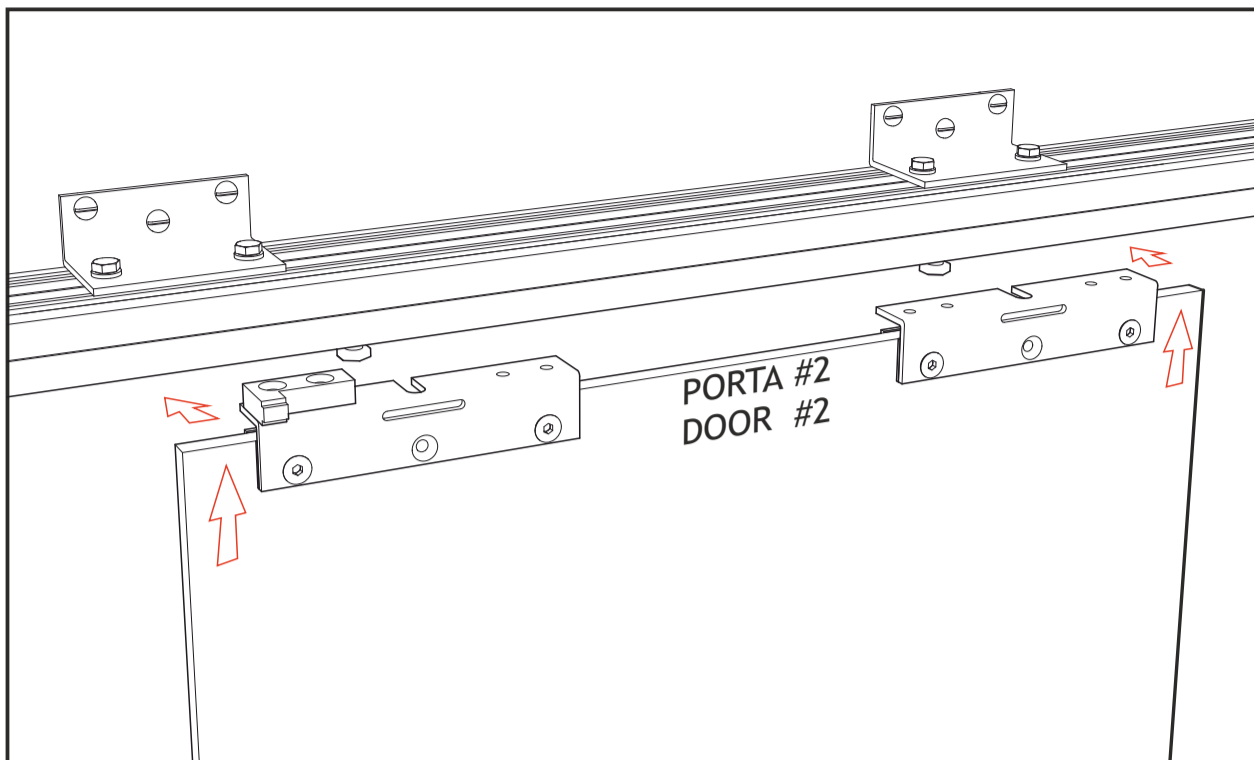

SENZA FISSO / WITHOUT FIXED GLASS

CON FISSO / WITH FIXED GLASS

